

Technical Data

Water capacity (incl. 1 person with 70 kg)	180 l
connection cold water	DN 15 1/2" male thread
connection warm water	DN 15 1/2" male thread
Drain size	DN 50
Power supply	230 V / 50 Hz / 16 A
Protection grade	IPX 5
Halogen light	12 V / 35 W
Flow rate tub spout	22,5 l/min
Flow rate bath tub filler (Exafill)	30 l/min
Maximum floor load	300 kg/m ²

Air System	
number of air jets	14
Power consumption	0,8 kW
Noise level	≤ 75 dB
Water System	
number of water jets	6
Power consumption	0,8 kW
Noise level	≤ 75 dB
Max. delivery rate	183 l/min

Dimensions

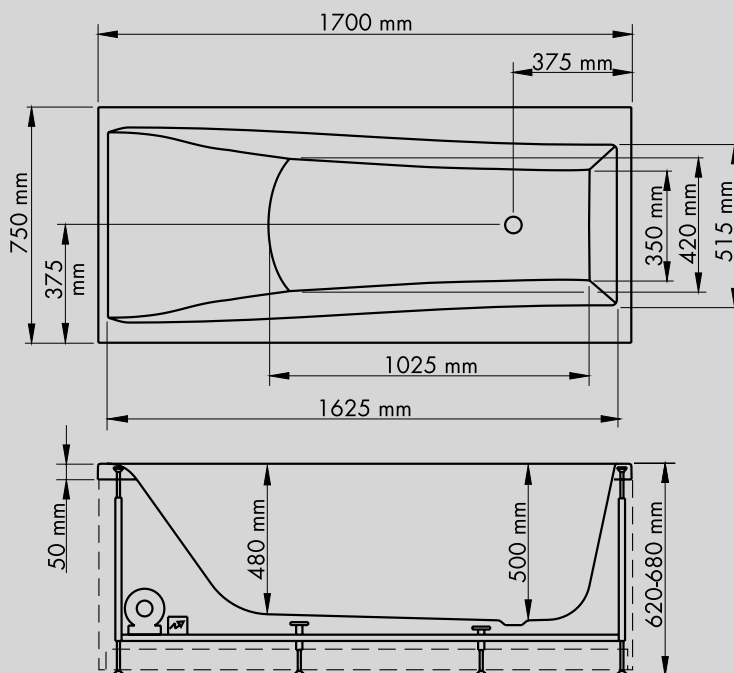

Packaging

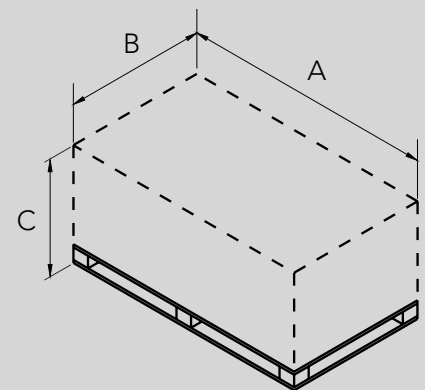

Carton	1
Weight (kg):	78
Side A (mm):	1845
Side B (mm):	895
Side C (mm):	940

Instructions for Installation

Pay special attention to the door width of the room where the Whirlpool will be installed and the openings through which the Whirlpool must be transported. They must be wider than the maximal depth of the Whirlpool.

The floor's carrying capacity must correspond to a load of 300 kg/m². The floor must be sufficiently levelled, i.e. it must be horizontal and even. Before installing the Whirlpool, the water supply pipes must be flushed according to the local regulations. During planning make sure that there are no cables under the bath tub or near the bath tub feet.

The Whirlpool can be installed on the wall side above the tiles or under the tiles. If side panels of Whirlpool Series 200 are used it is only possible to install the Whirlpool above the tiles. If the Whirlpool is installed in a completely tiled situation (without side panels), then there must be a service opening, at least 600 x 400 mm in size, positioned near the pump and blower. This service opening should be installed so that you can access and replace parts such as the blower, pump, valves, terminal box and other connections at any time. Removable side panels are ideal for this purpose. An air grid (only for Whirlpool with air system) with min. 150 cm² is

mandatory. The grid can be located in a neighbouring room. The air supply will be guaranteed without separate air grid if side panels for Whirlpools are used.

The entire power supply must be made via a 230 V/N/PE/50Hz AC connection with a main switch (conductor with an opening of 3 mm) for switching off the power supply. The power supply must be fused via a 2-pole RCD with a residual current of ≤ 30 mA.

Electrical connection: cable 3 x 1.5 mm² / cable length 3500 mm.

Equipotential bonding: cable 4 mm² / cable length 3500 mm.

References

- LT1, LT2 service opening area for maintenance (dimensions 600x400mm)
 - LA service opening for bath mixer
 - 1 Recommended position for cold water connection (right) and hot water connection (left) DN 15.
 - 2 Recommended position for the water drainage Ø 50 (floor: upper rim of connection pipe flush with tub feet contact area).
 - 3 The electrical supply and the earth cable connection* are made out of the wall.
- * Cross-section at least 4 mm²

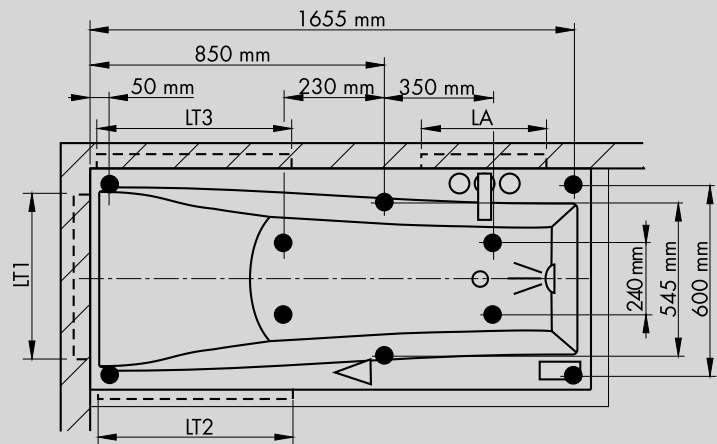
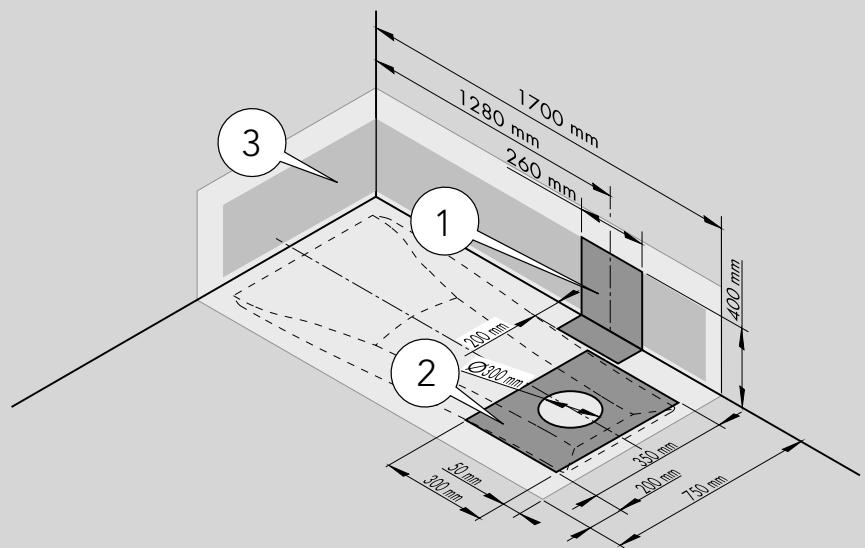

Keep an adequate distance to the outer edges of the tub!

- Tub feet
- ▲ Mini Poolmaster
- Poolmaster
- ⋮ Water inlet combination
- ◀ Halogen light