

Technical Data

Water capacity (incl. 1 person with 70 kg)	235 l
Connection cold water	DN 15 1/2" male thread
Connection warm water	DN 15 1/2" male thread
Drain size	DN 50
Power supply	230V / 50 Hz / 16 A
Protection grade	IPX 5
Halogen light	12V / 35 W
Flow rate bath tub filler (Exafill)	30 l/min
Maximum floor load	300 kg/m ²

Air System	
Number of air jets	16
Power consumption	0,7 kW
Noise level	≤ 75 dB
Water System	
Number of water jets	8
Power consumption	0,8 kW
Noise level	≤ 75 dB
Max. delivery rate	183 l/min

Dimensions

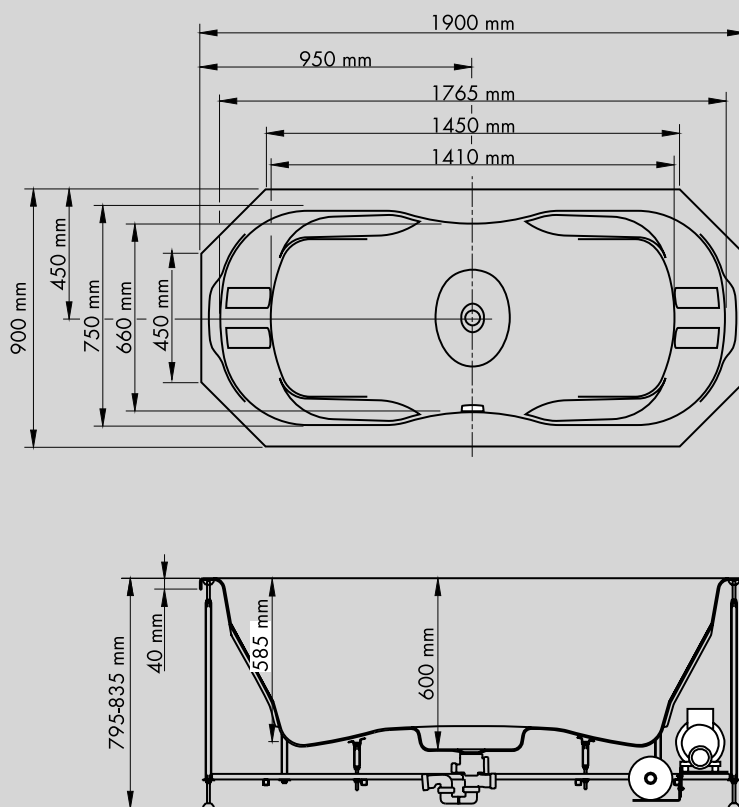

Packaging

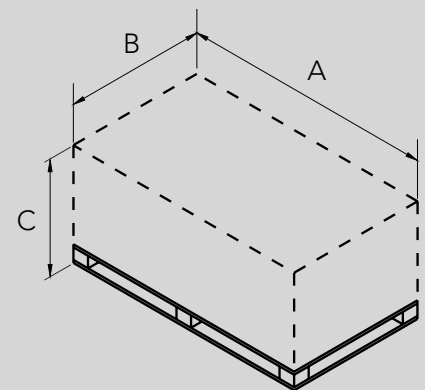

Carton	1
Weight (kg):	90
Side A (mm):	2000
Side B (mm):	1150
Side C (mm):	1050

Instructions for Installation

Pay special attention to the door width of the room where the Whirlpool will be installed and the openings through which the Whirlpool must be transported. They must be wider than the maximal depth of the Whirlpool.

The floor must be sufficiently levelled, i.e. it must be horizontal and even. Connections for water supply have to be installed according to the currently valid DIN 1988 / EN 1717 and DIN 1986 / EN 12056 as well as to the local regulations. During planning make sure that there are no cables under the bath tub or near the bath tub feet.

If the Whirlpool is installed in a completely tiled situation (without side panels), then there must be a service opening, at least 600 x 600 mm in size, positioned near the pump and blower. This service opening should be installed so that you can access and replace parts such as the blower, pump, valves, terminal box and other connections at any time. Removable side panels are ideal for this purpose. An air grid (only for Whirlpool with air system) with min. 150 cm² is mandatory. The grid can be located in a neighbouring room. The air supply will be guaranteed without separate air grid if side panels for Whirlpools are used.

The entire power supply must be made via a 230V/N/PE/50Hz AC connection with a main switch (conductor with an opening of 3mm) for switching off the power supply. The power supply must be fused via a 2-pole RCD with a residual current of ≤ 30 mA.

Electrical connection: cable 3 x 1.5 mm² / cable length 3500 mm.

Equipotential bonding: cable 4 mm² / cable length 3500 mm.

References

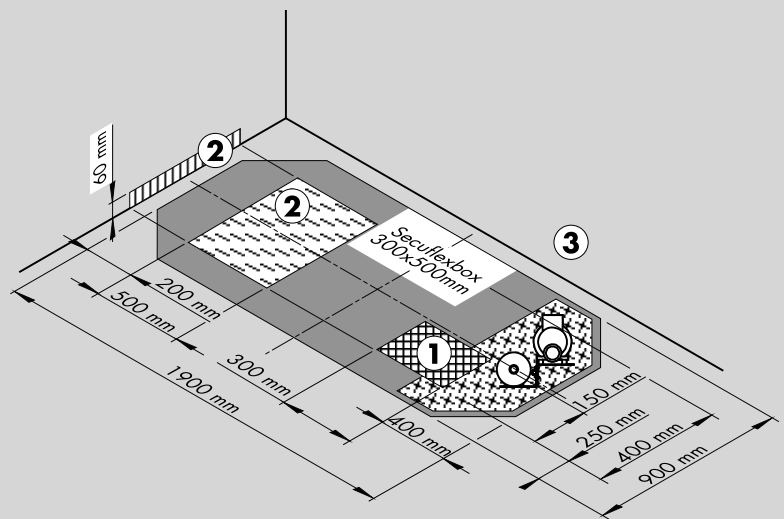

B1, B2 possible service opening area for maintenance maintenance on left side (dimensions 600x600mm)

1 Only for whirlpools with bath mixer: Recommended position for cold water connection (right) and hot water connection (left) DN 15.

2 Recommended position for the water drainage Ø 50

floor: upper rim of connection pipe flush with tub feet contact area

wall: lower rim of connection pipe flush with tub feet contact area

3 The electrical supply* and the earth cable connection** are made out of the wall.

* cable 3 x 1.5 mm² (connected load max. ≤ 3.2 kW) or cable 4 x 2.5 mm² (connected load max. > 3.2 kW) cable length: 3500 mm

** Cross-section at least 4 mm² cable length: 3500 mm



Keep an adequate distance to the outer edges of the tub!

● Tub feet

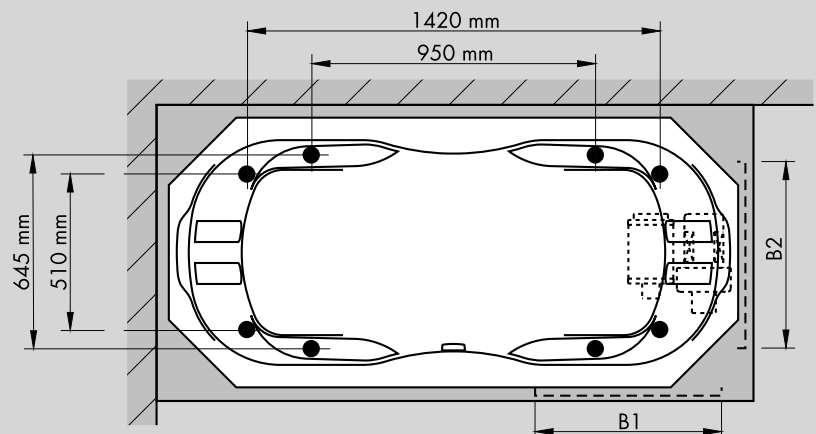

Whirlpool Ladiva 760