

Technical Data

Required room height from shower tray	2,1 m
Minimum flow pressure	1,5 bar
Recommended flow pressure	2 - 5 bar
Suitable for continuous flow heaters from	24 kW
Connection cold water	DN 15 1/2"
Connection warm water	DN 15 1/2"

Flow Pressure Diagram

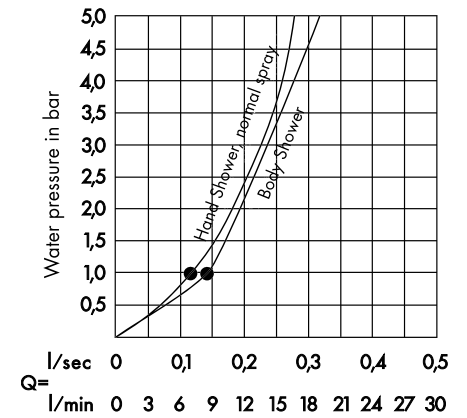

Dimensions

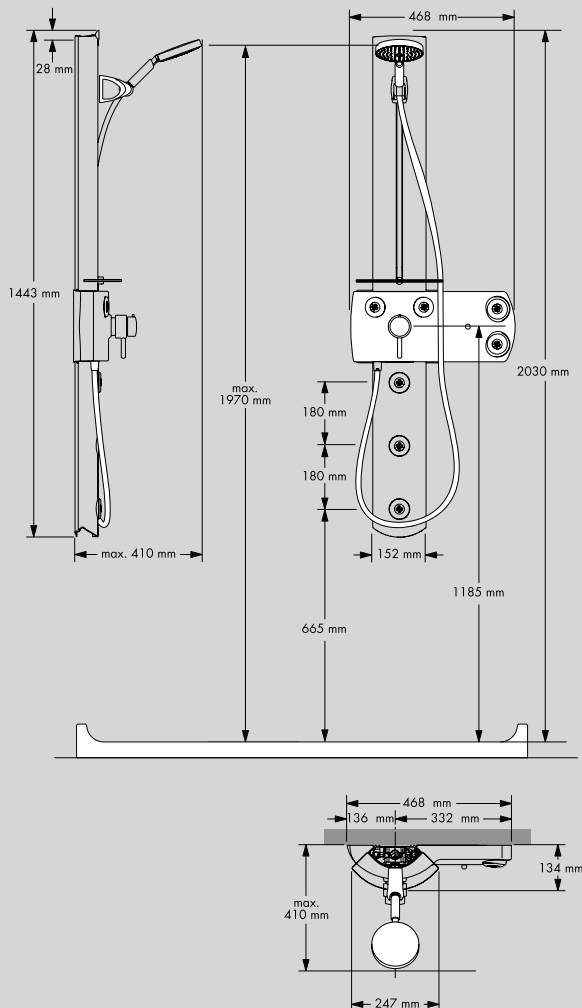

left an right version available

Packaging

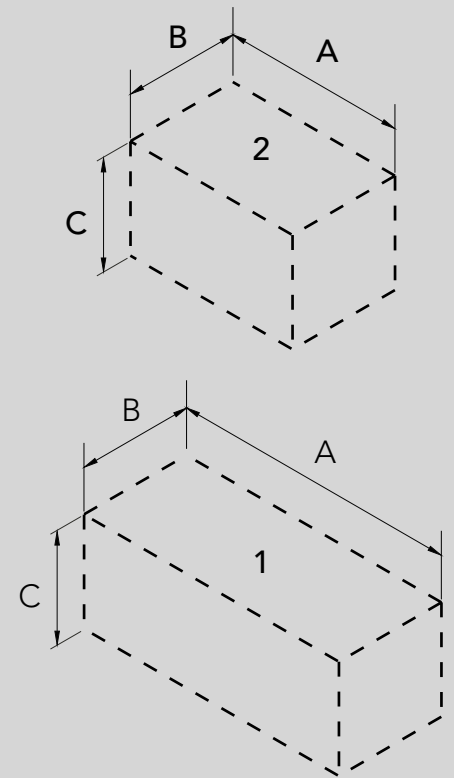

Carton	1	2
Weight (kg):	13	2
Side A (mm):	1528	700
Side B (mm):	292	300
Side C (mm):	222	170

Showerpanel Comfort Plus Triostat with Renovation Kit Wall

Instructions for Installation

Connections for water supply have to be installed according to the currently valid DIN 1988 / EN 1717 and DIN 1986 / EN 12056 as well as to the local regulations.

References

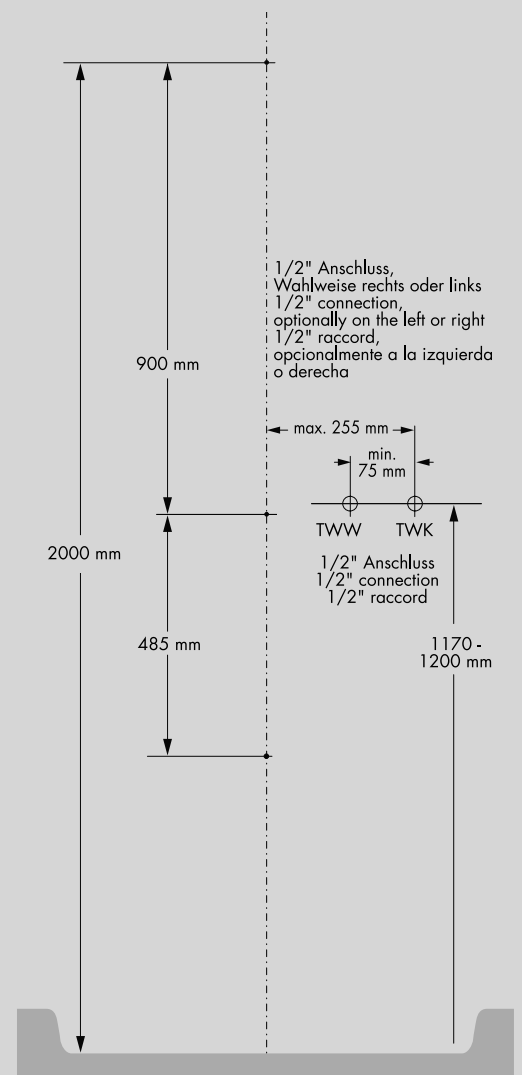

TWW hot water (DN 15 1/2")
TWK cold water (DN 15 1/2")

left an right version available

Showerpanel Comfort Plus Triostat with Renovation Kit Wall